



**Aurora Labs<sup>®</sup>**

TECHNOLOGY UPDATE

ASX : A3D

# Technology Update

2015 /  
RAPID MANUFACTURING TECHNOLOGY (RMT)

---

Aurora has been developing the Rapid Manufacturing Technology (RMT) since our inception 4 years ago. The development of such a transformative technology is not an easy task but the dedicated team of talented engineers and other professionals has persisted to the point that we have now been regularly printing parts for over a year.

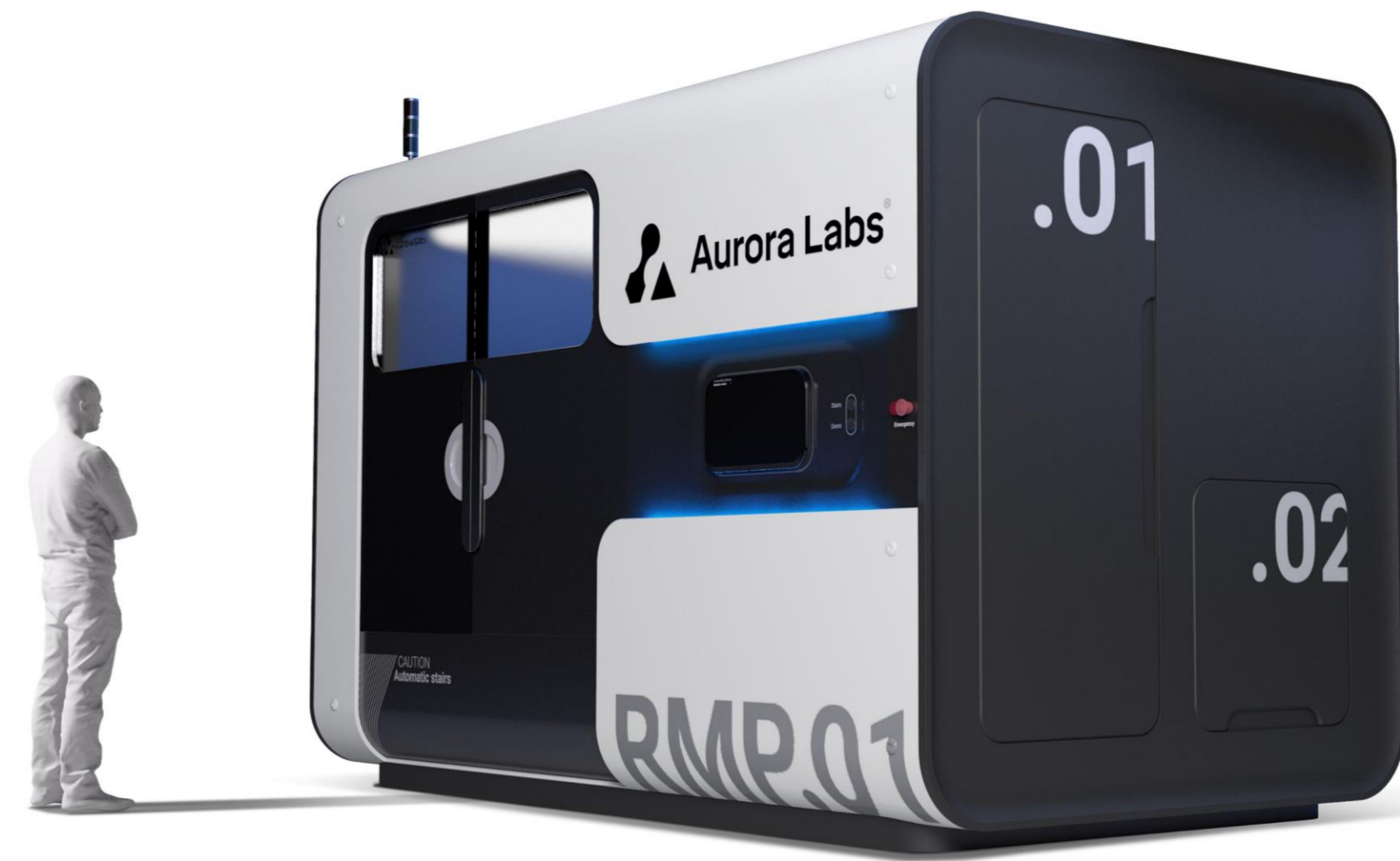
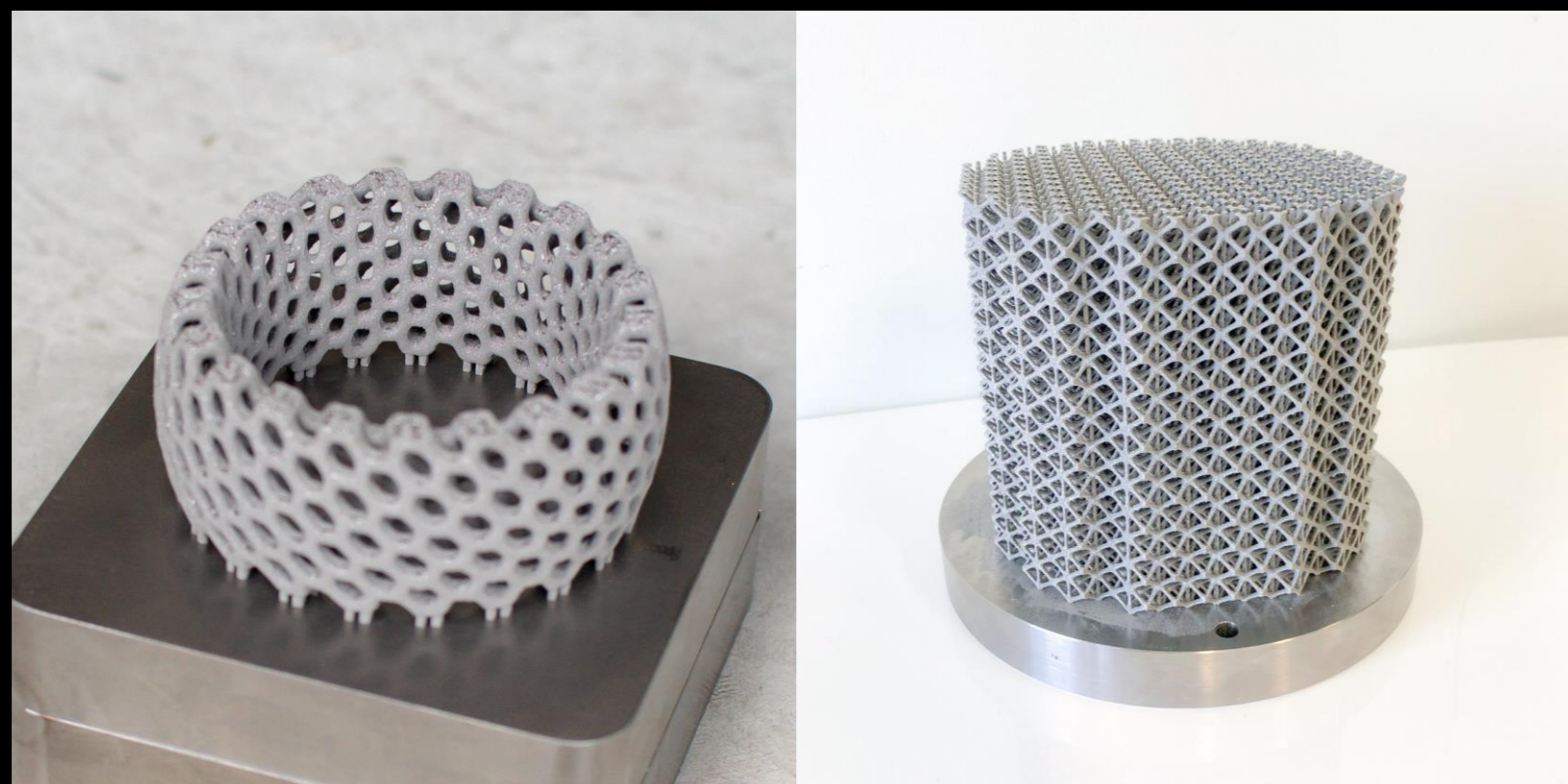

2019 /  
RMP1 - BETA

---

This iterative process has necessitated the development and building of several Alpha printers to prove the various technologies now incorporated into the RMP 1 – Beta. This technology update will give some insight into the very significant progress we have made into developing the technology to maturity although full realization is not yet complete.

IMAGES

---

Left 1 / Complex titanium bracelet printed with Apha RMT machine  
Left 2/ Complex geometric mesh printed in titanium with Alpha 2 RMT machine  
Above / RMP1-Beta

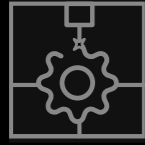

PRINTERS

# Alpha

Printing since 7 Sep 2018

Build Volume 180mm diameter  
120mm tall

Materials Printed  
AlSi10Mg  
Aluminium Proprietary Alloys  
316L SS  
Ti CP grade 1 & 2  
Ti grade 5

Printing Tests Completed 187\*

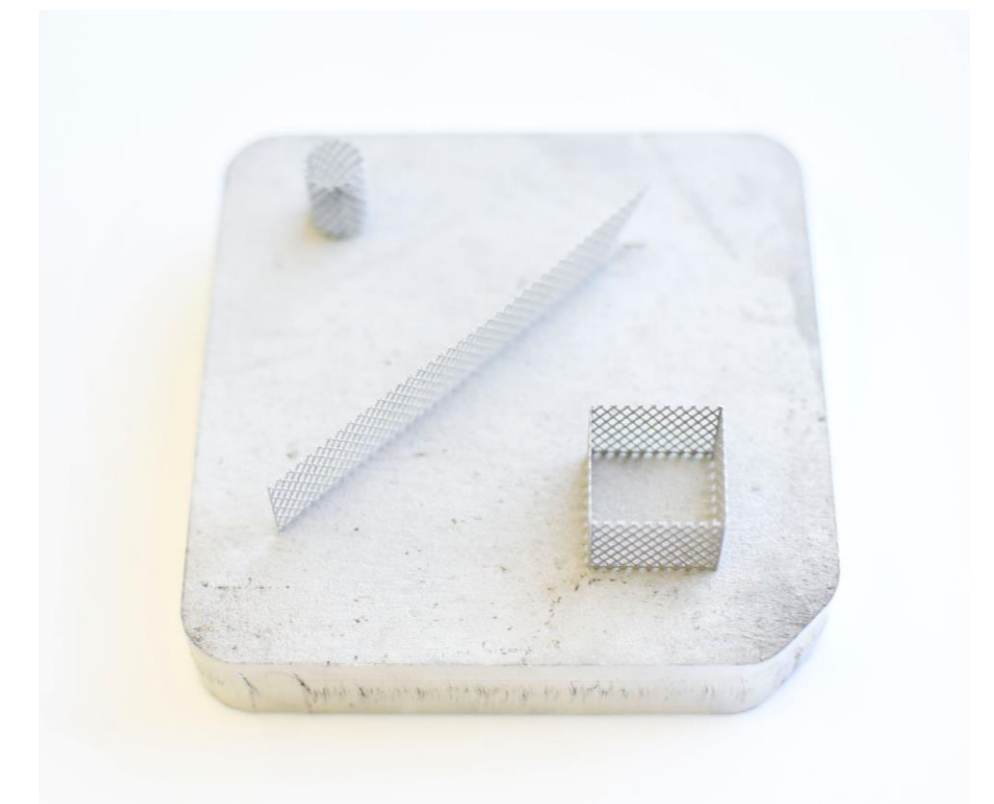
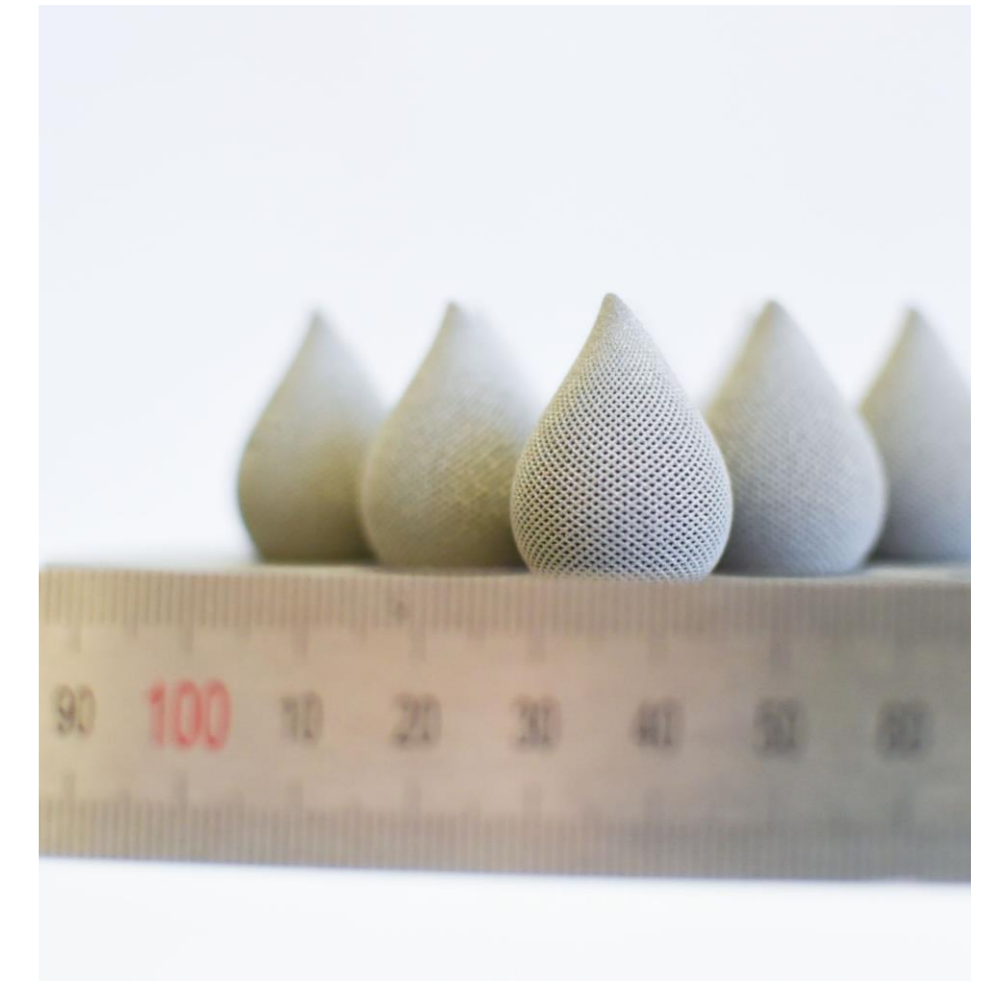
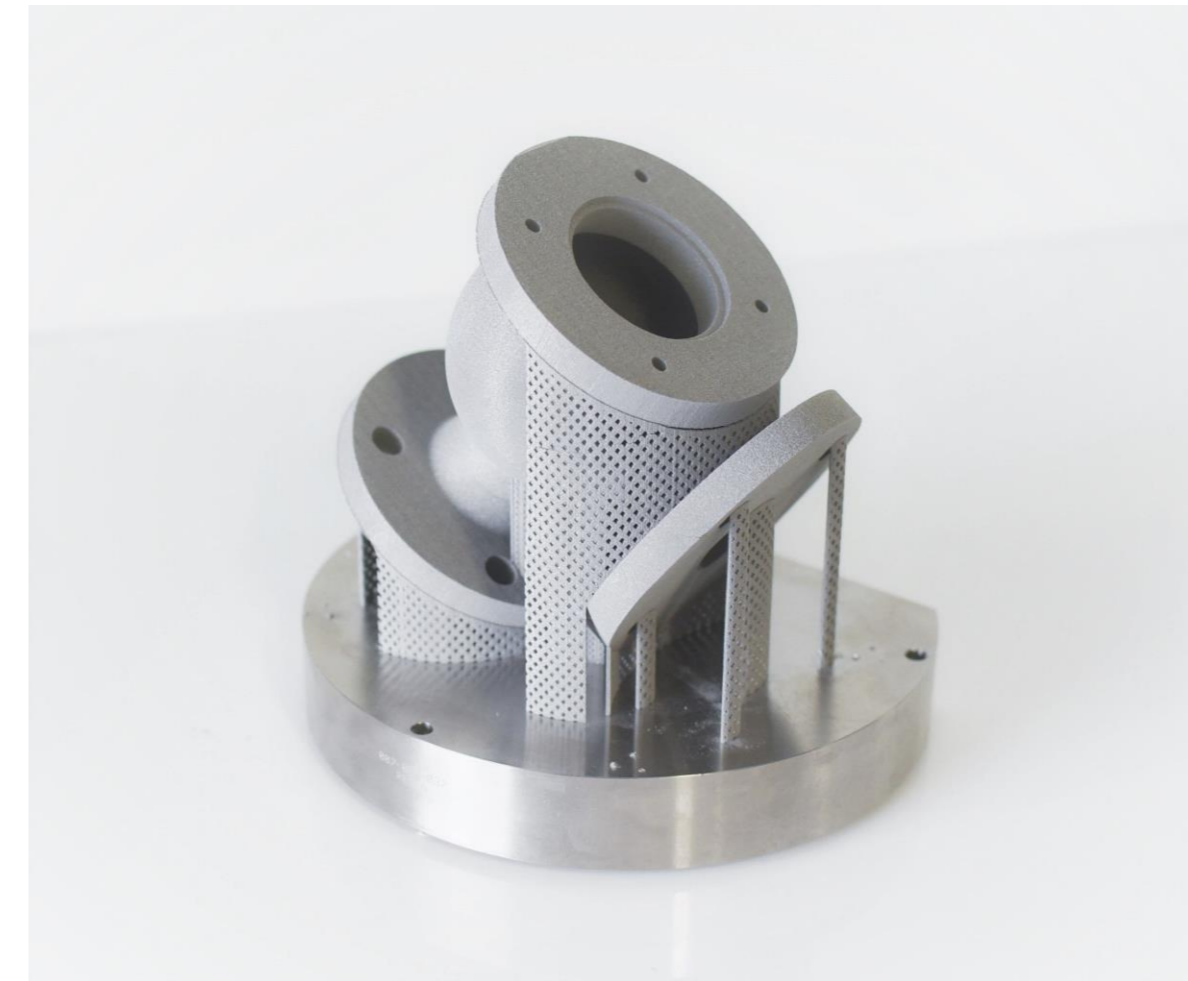

## IMAGES

Top Left / High complexity bracelet printed by Alpha RMT machine  
Top Right / High complexity bracelet printed by Alpha RMT machine  
Bottom Left / High complexity bracelet printed by Alpha RMT machine  
Bottom Right / High complexity bracelet printed by Alpha RMT machine

\*\*Printing Test are only one measure of many of the progress in the printers development. Other items include test coupon printing, where up to 16 cubes or more can be printed on a single plate then analysed, software modifications, where software is modified and upgraded then tested to see the results of the upgrade. Each one represents a number of learnings that may require hardware, software and process changes or a combination of all of these. We are past the most difficult stage but we continue to strive to develop the most efficient production printer available.

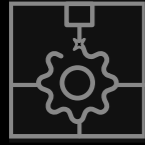

PRINTERS

# Alpha 2

Printing since	12 Feb 2019
Build Volume	190mm diameter 130mm tall
Materials Printed	Ti CP Ti gr 5 17-4PH
Printing Tests Completed	100*

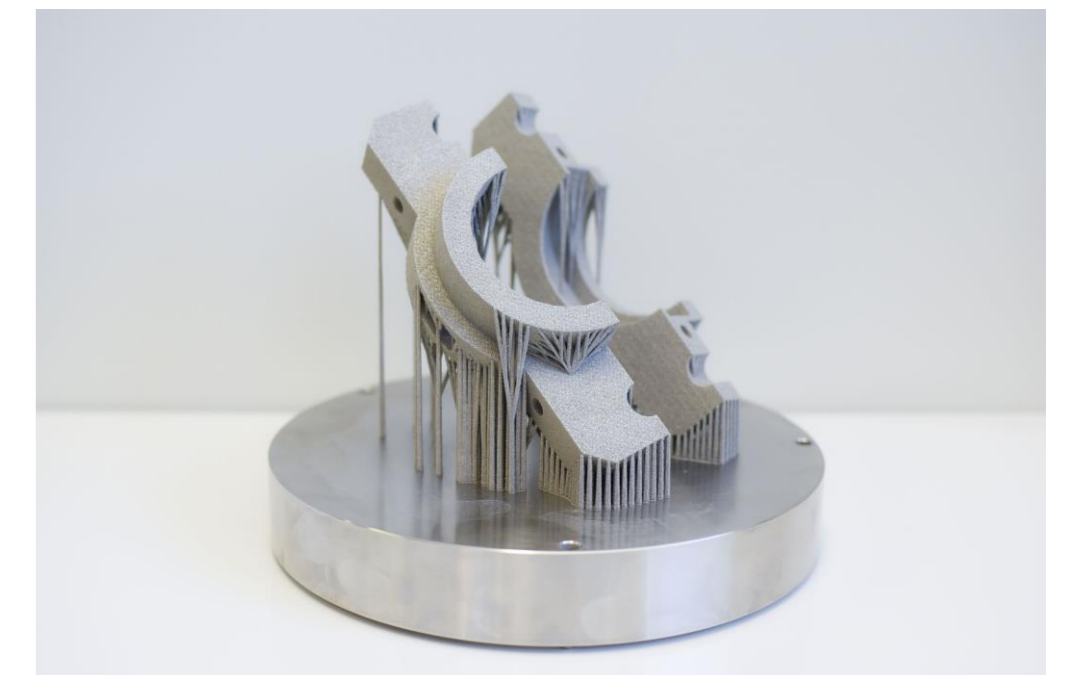
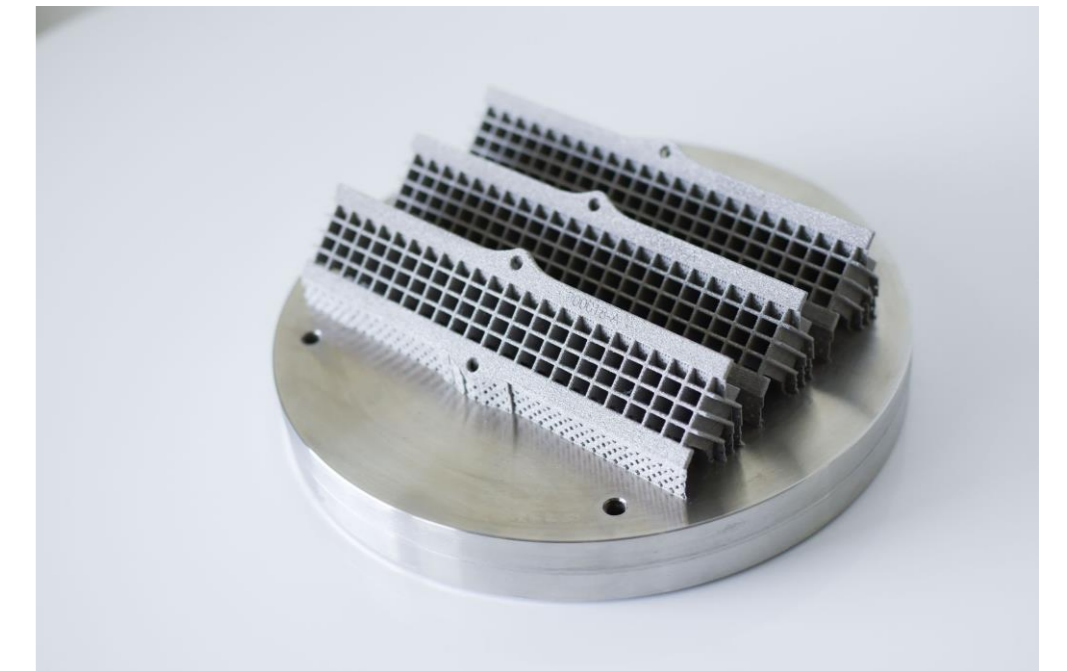
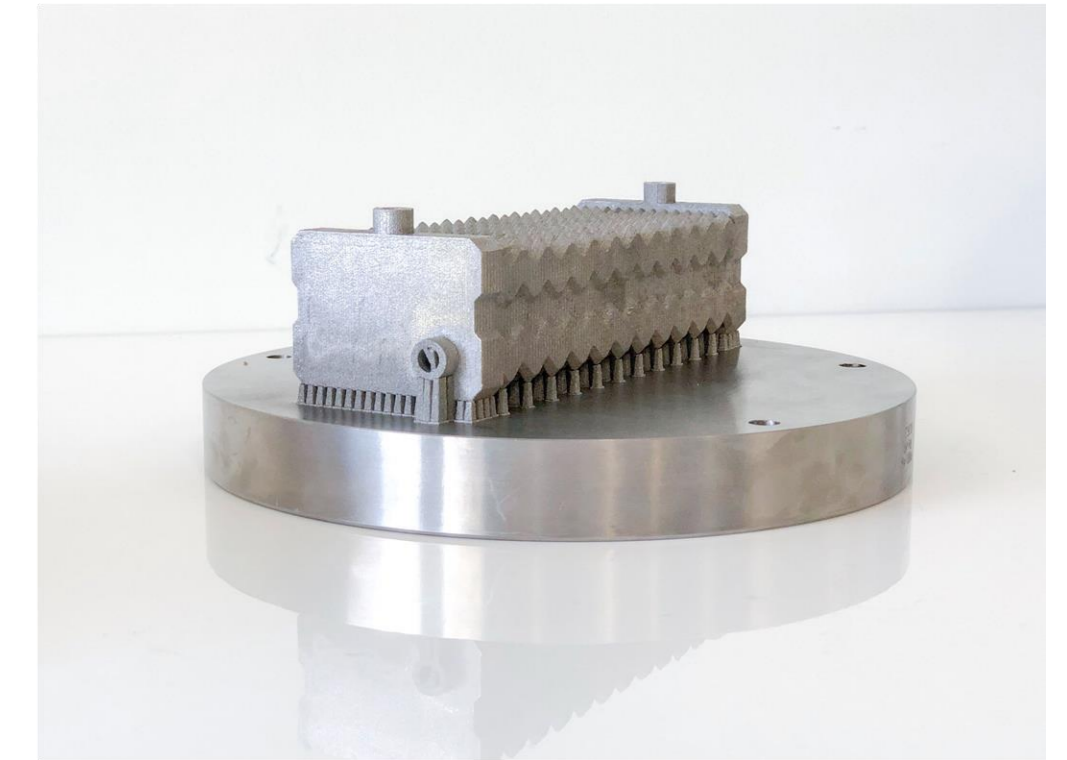
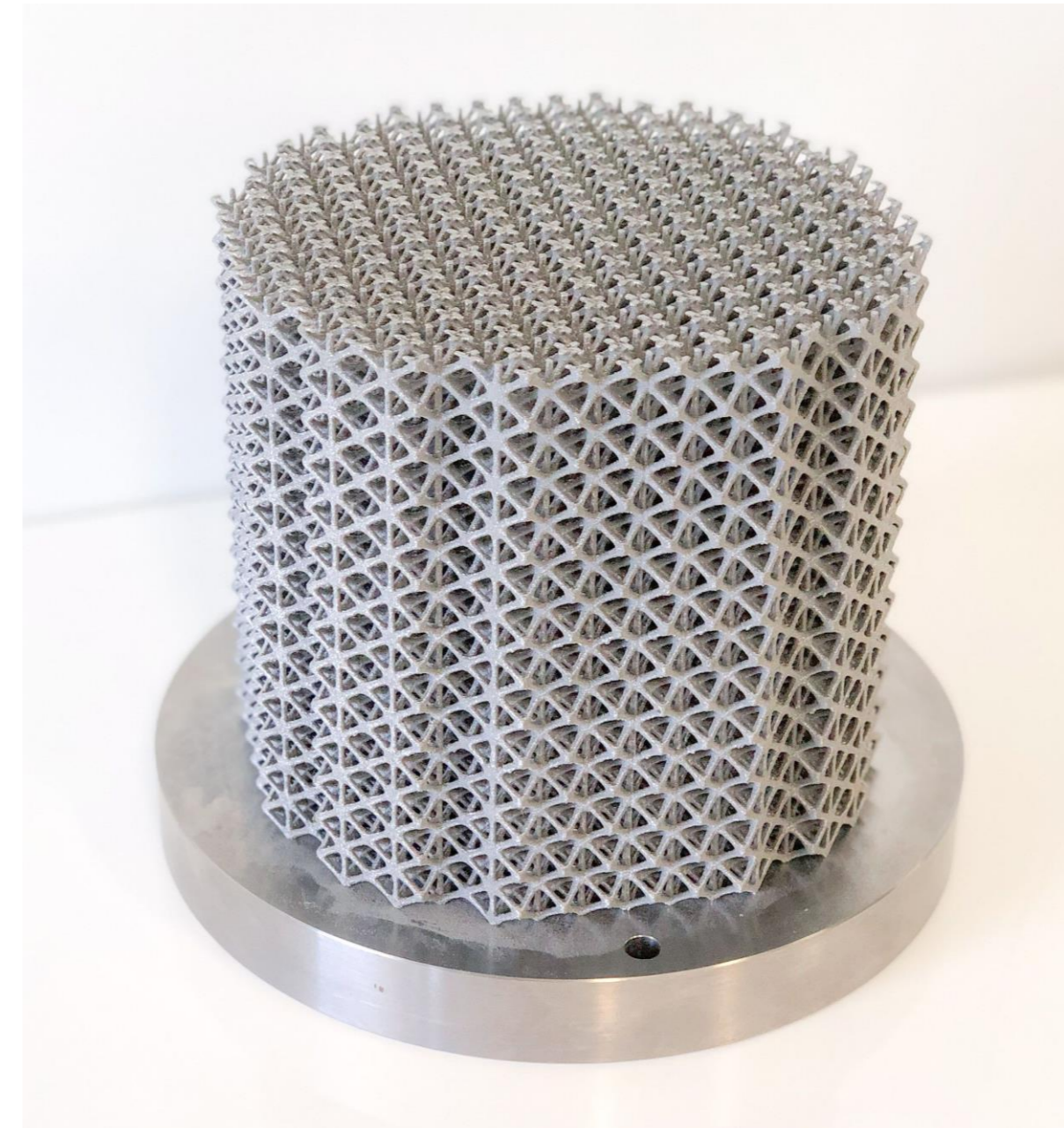

## IMAGES

Top / High complexity bracelet printed by Alpha RMT machine  
 Right Top / Titanium  
 Right Middle / Aluminum  
 Right Bottom / Aluminum

\*Printing Test are only one measure of many of the progress in the printers development. Other items include test coupon printing, where up to 16 cubes or more can be printed on a single plate then analysed, software modifications, where software is modified and upgraded then tested to see the results of the upgrade. Each one represents a number of learnings that may require hardware, software and process changes or a combination of all of these. We are past the most difficult stage but we continue to strive to develop the most efficient production printer available.

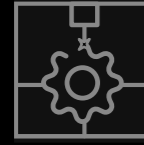

PRINTERS

# RMP-1 BETA

Printing since 27 June 2019

Beta build Volume 420mm diameter 400mm tall

Production Machine 450mm diameter 400mm tall

Commissioning Test 316L SS Powder

Materials Printed Ti CP  
Ti gr 5  
17-4PH

Print Lots Completed 36\*  
With up to 100 parts per lot.

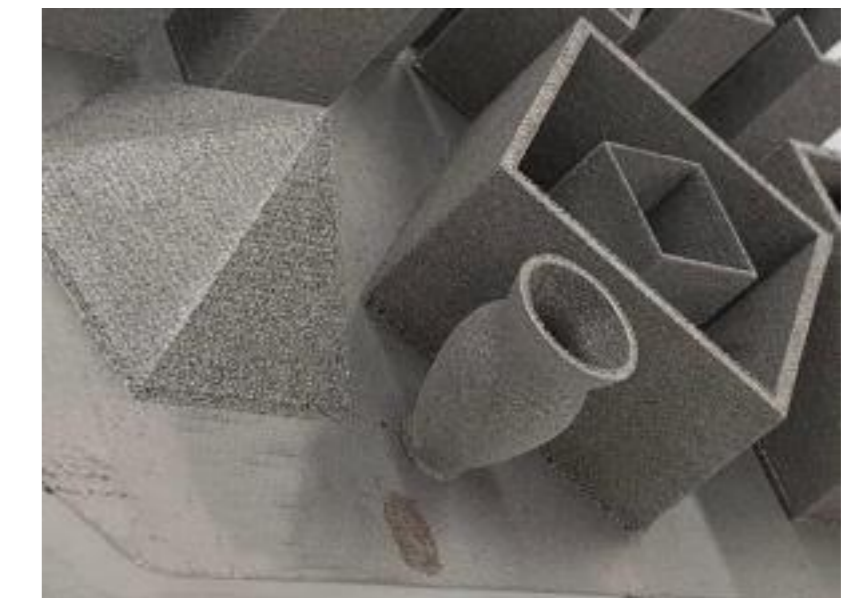
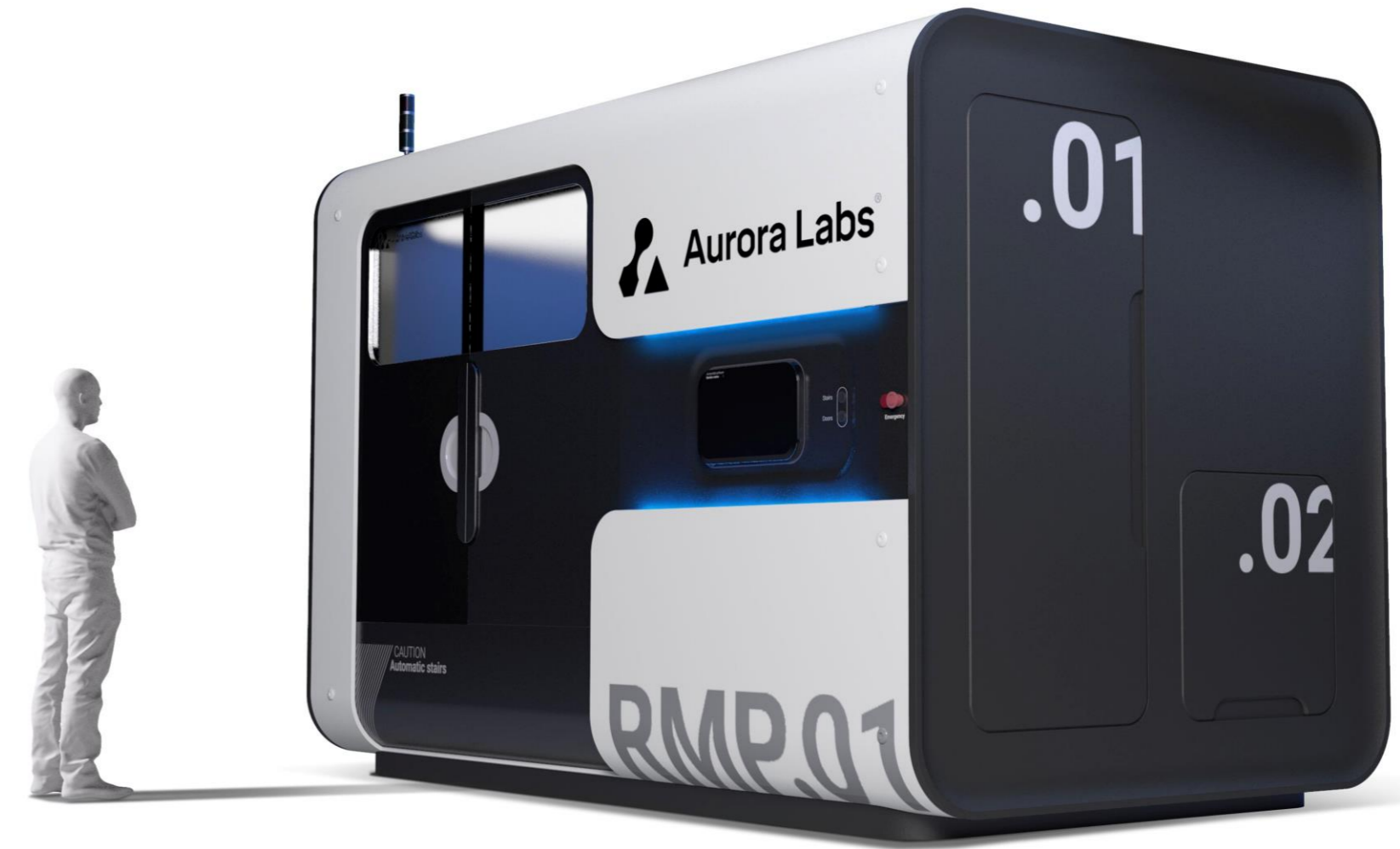

## IMAGES

Top / RMP-1 Beta

Bottom Left / High complexity bracelet printed by Alpha RMT machine

Bottom Right / High complexity bracelet printed by Alpha RMT machine

\*Printing Test (see on next slide – Print test)

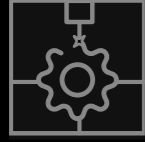

## \* Testing

A print test can represent individual printed parts but are more often **multiple parts and/or parameters on the same print plate**.

The highest number of parts printed to date on a single plate is 99.

Excluded from the print tests are parameter tests, where we print many individual variable cubes for analysis. There have been hundreds of these.

While we have printed hundreds of parts we often cannot reveal the nature of the components as they are being printed under non-disclosure agreements with our clients

For example we recently completed a test print for a large European automotive manufacture printing 99 parts in a single print.

# UNRIVALLED PRINTERS

RMP printers use patent pending Multi-layer Concurrent Printing (MCP™) technology to print multiple metal layers in a single sweep.

This increases production speed, and allows high accuracy at high speed which is unachievable in single layer printers.

Laser melting means no binders.  
Our process is complete as printed.

Click below to:

- [Watch explanatory MCP™ animation](#)
- [Watch MCP multi layer printing](#)

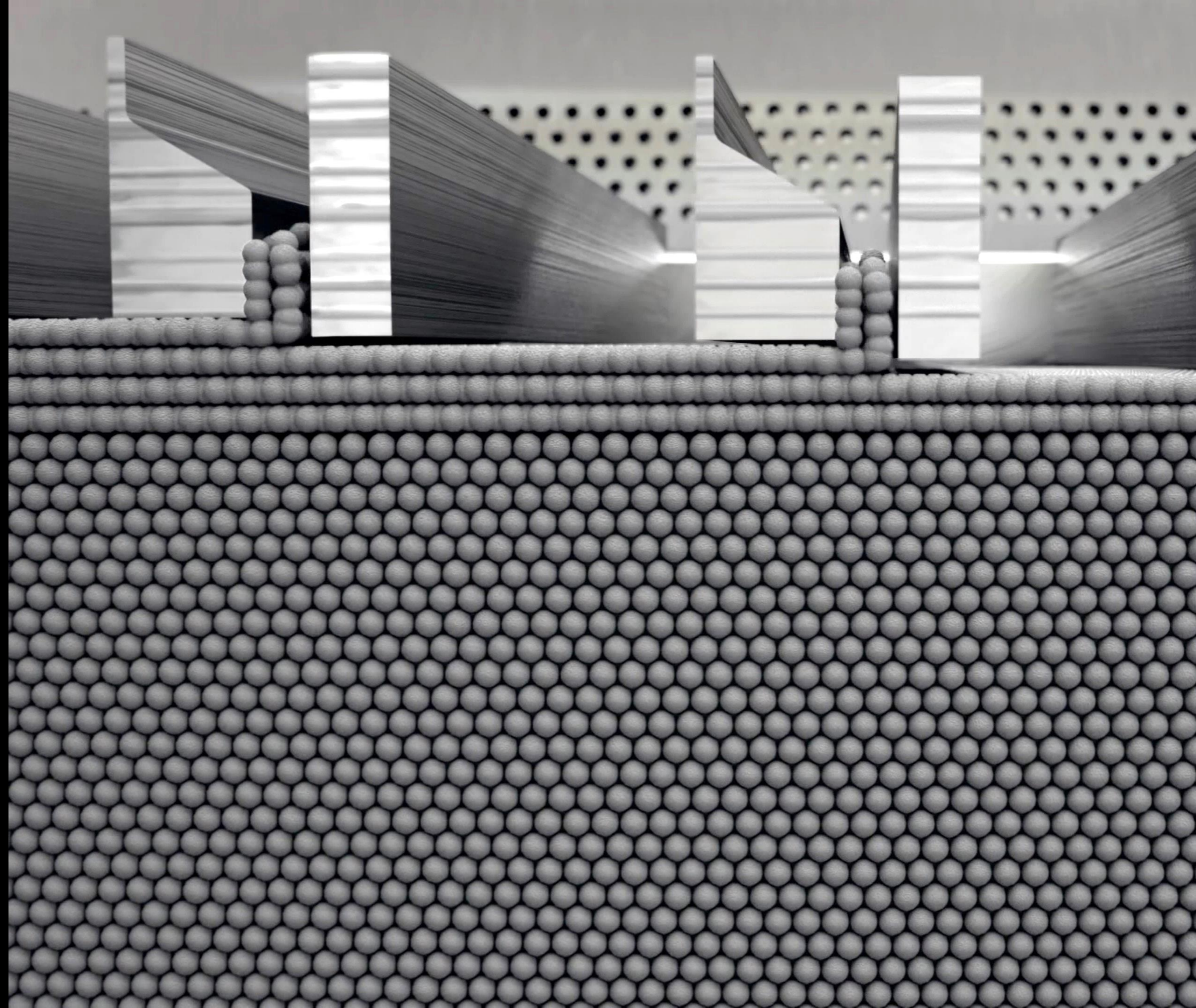

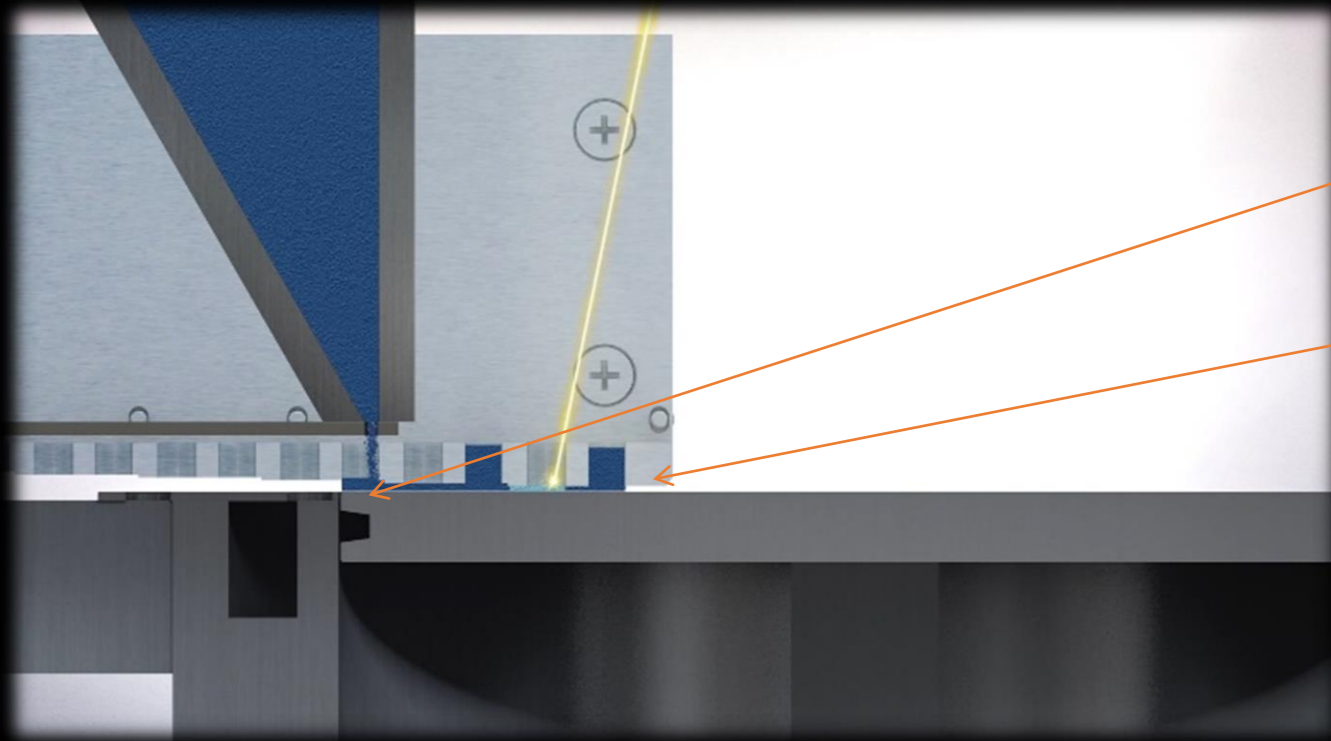

Powder drop  
Powder level lowers as  
Bed is coated for layer 1

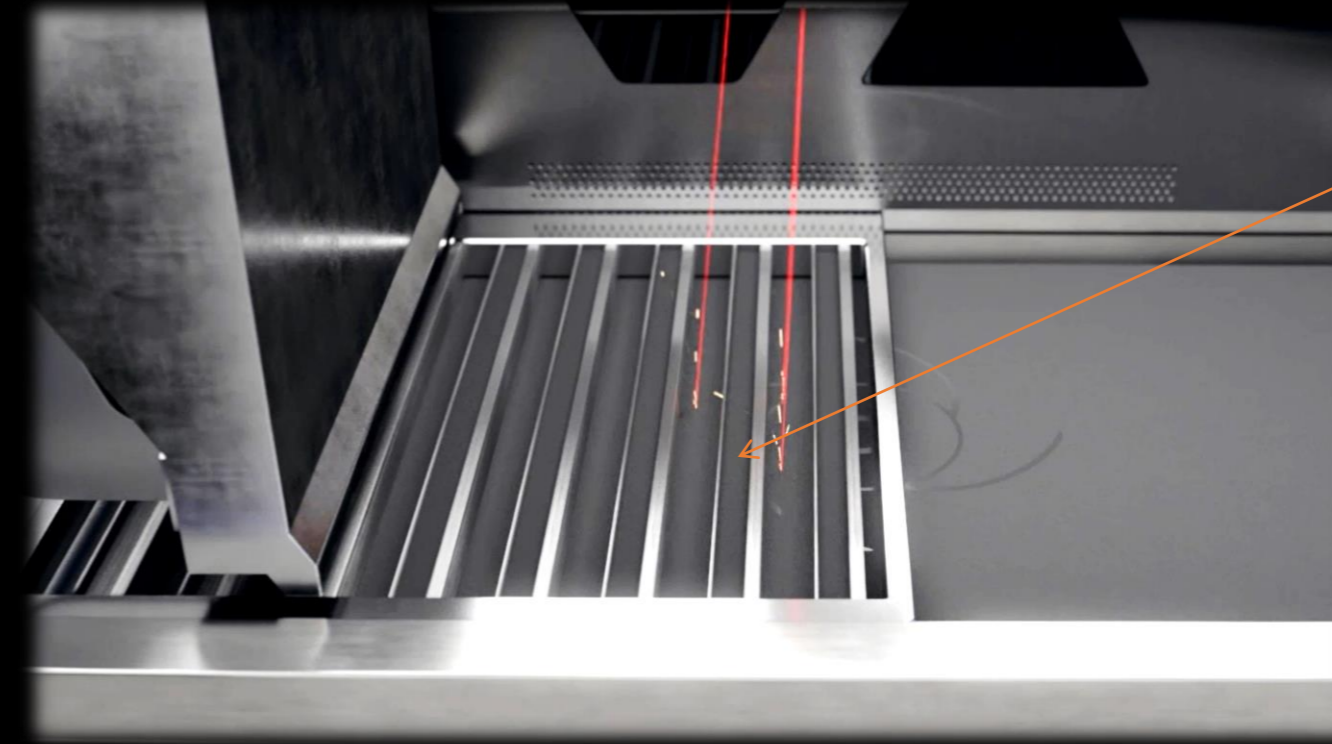

Lasing on multiple levels

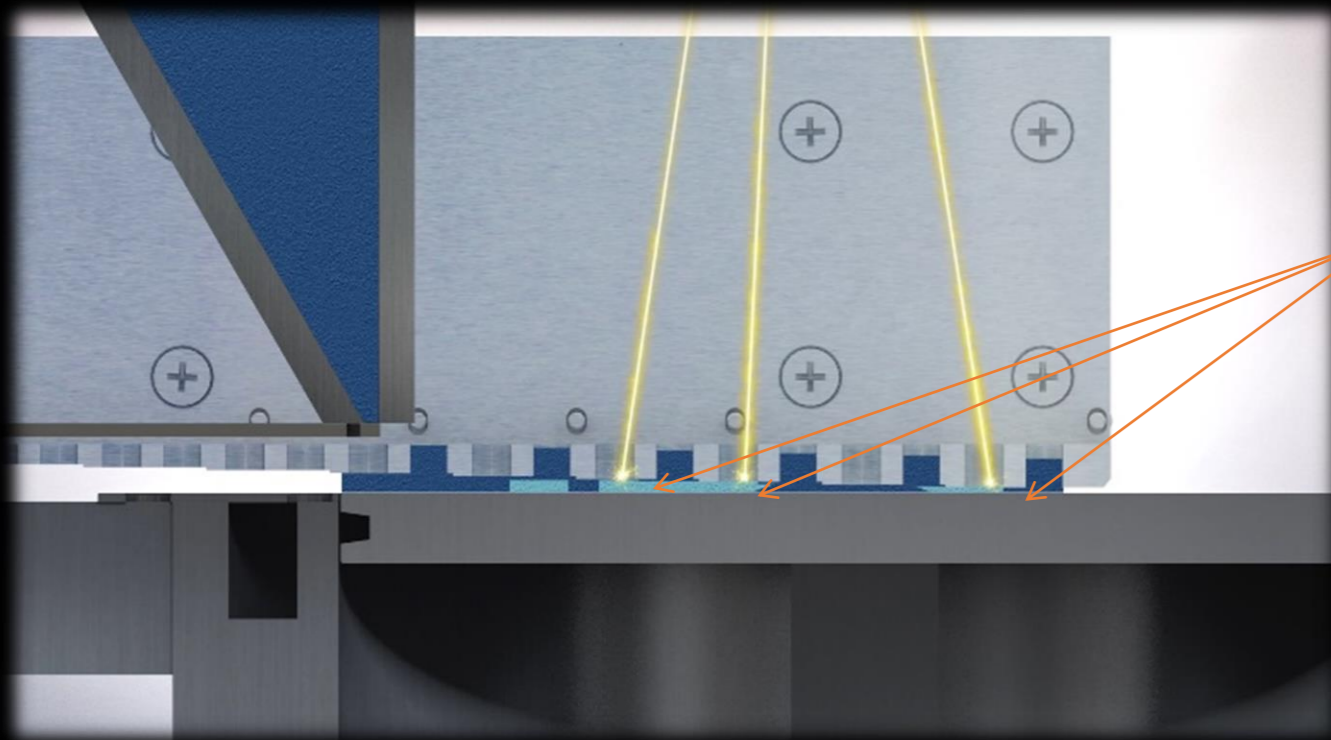

Lasing on operative  
surface  
Layers 1,3 and 4

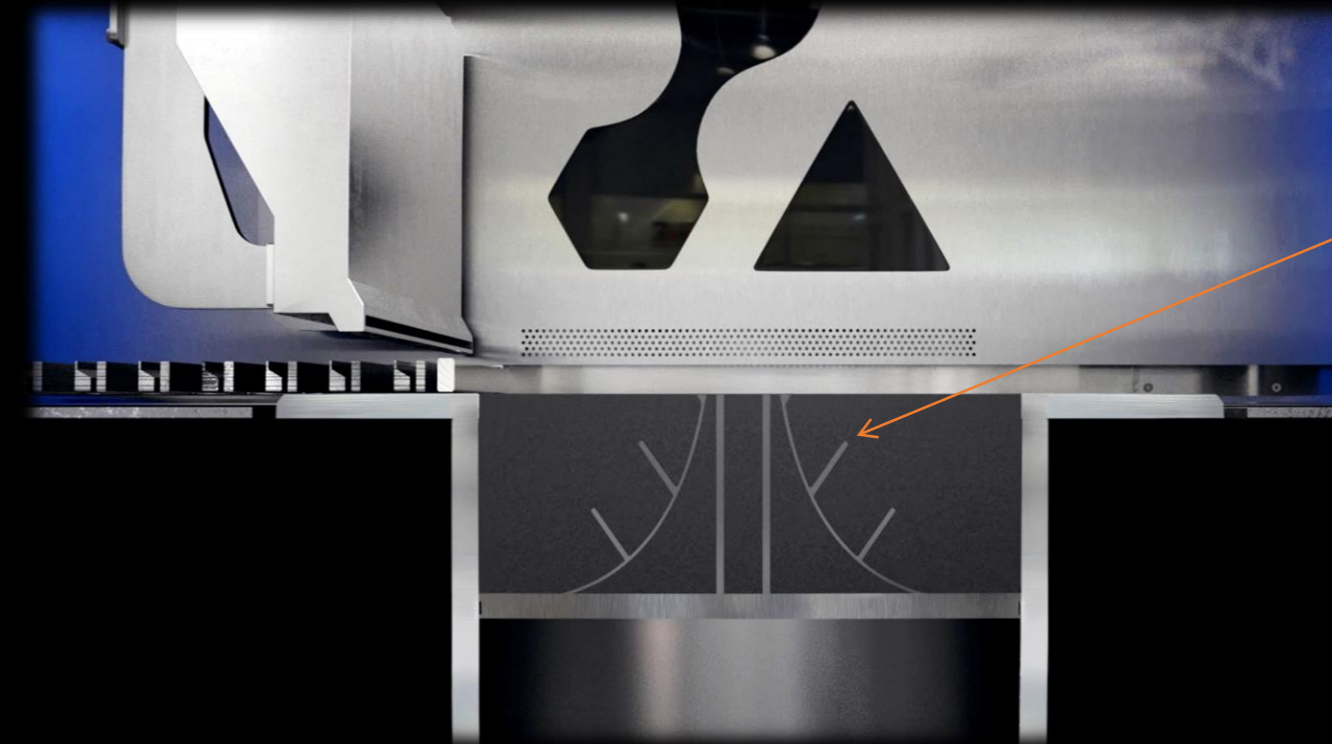

Part takes shape  
under powder bed

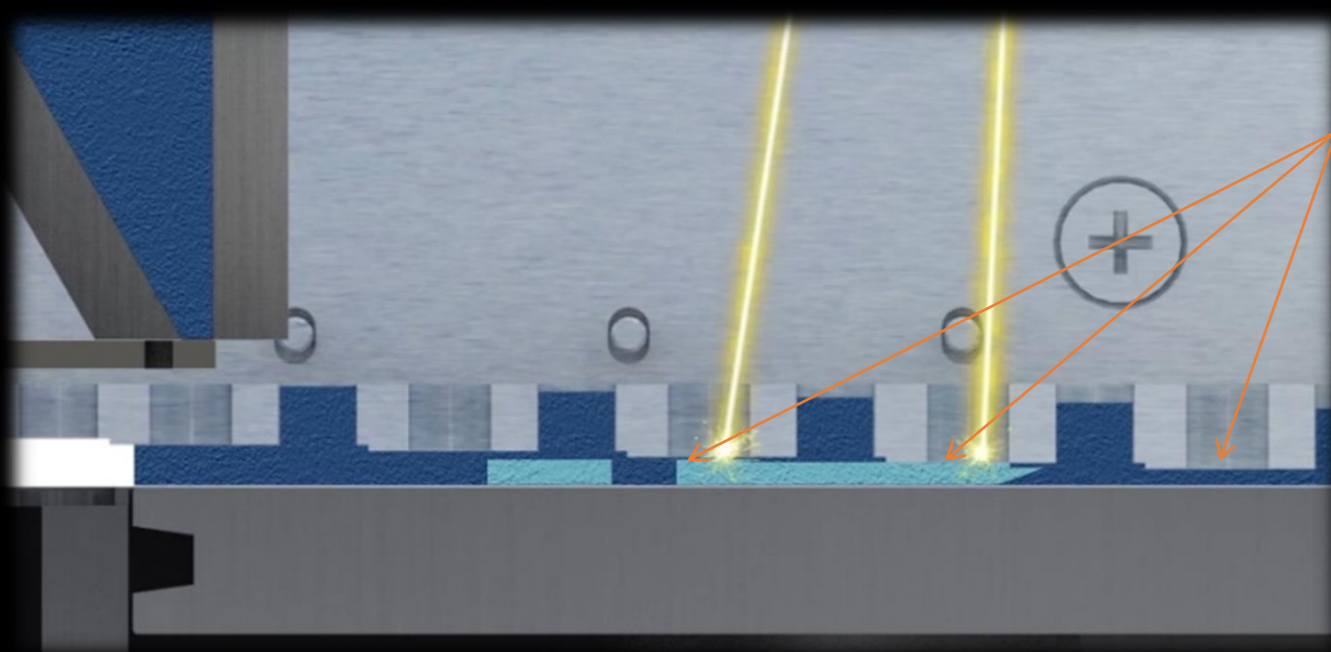

Each layer has increased distance  
to bed plate by a set height

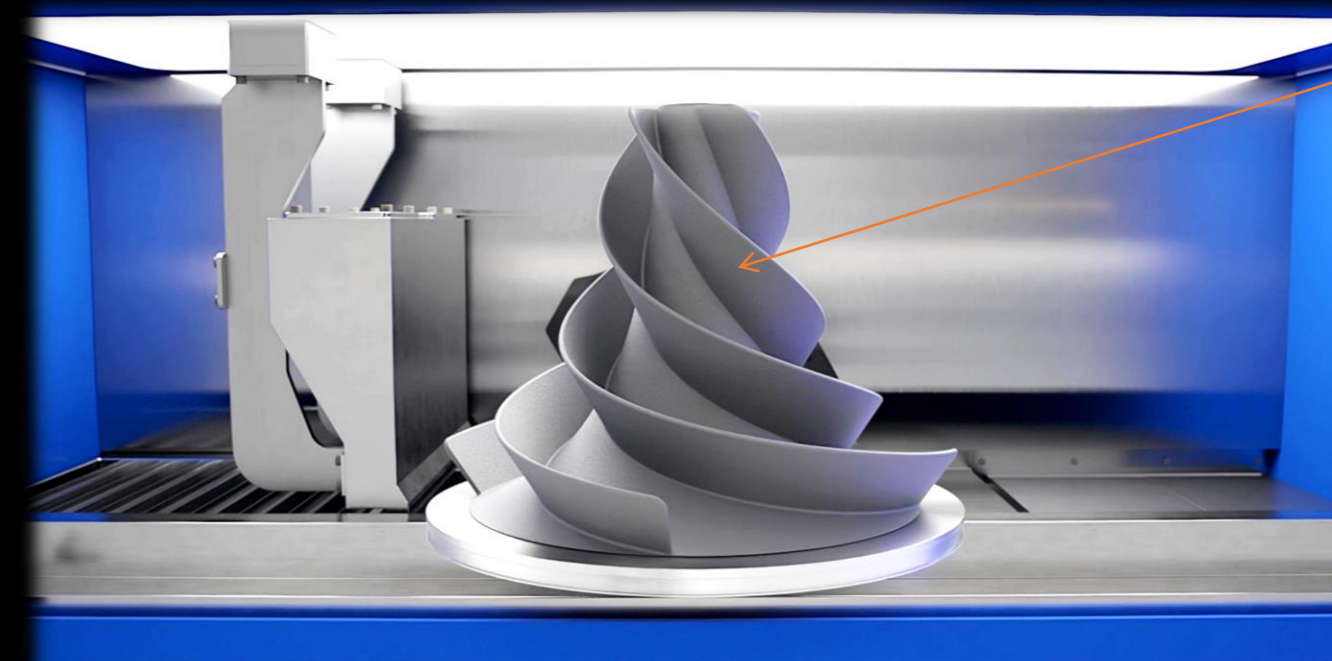

Completed part  
removed with build  
plate



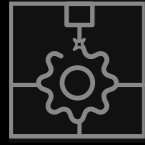

# THE FUTURE

## RMP-2: Large format 3D printer

- Ongoing Research and Development Project
- Revolutionary speed goal of 1 tonne per day
- Build volume target in excess of 1.5 cubic metres

Targeted to deliver the previously unattainable goal of printing with speed, accuracy and low cost, on a scale that challenges conventional metal manufacturing.



# Industry Engagement

Industry Partner Program (IPP) established to give potential RMP users:

- Early access to our printer technology,
- Participation in joint development projects,
- Priority printer purchase and
- Participation in market development

In advanced discussion with many Tier 1 companies behind Mutual Non-disclosure Agreements (MNDA).

## BREADTH OF INTEREST FROM TIER 1 COMPANIES BY INDUSTRY SECTOR



4 Automotive / Transport



1 Marine



3 Aviation / Aerospace



1 Medical



7 Industrial



2 Mining



1 Oil & Gas

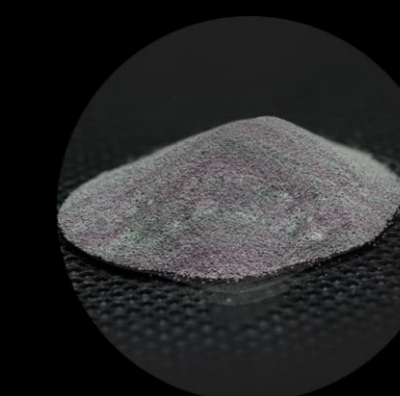

2 Advanced Materials

# Industry Partner Program Update



AdditiveNow

Work by the Joint venture continues and as previously disclosed the relationship includes a purchase agreement for the RMP-1 Beta to satisfy demand from customers.



VEEM

The size of parts required by VEEM means practical use of the RMP technology for production will need a larger model. Special materials required for the project have been sourced. Preliminary testing of material will begin in 2020.



UWA/RPM

Agreement now signed by all parties and Printer has been optimised, personnel trained and project completion is expected in 3-6 months.



FMG

The previous term sheet has expired and discussions are continuing as to whether changes may be required to reflect current requirements.



Granges

There is continued progress with Granges AB to convert the Company's MOU into a formal agreement. "We have held successful meetings with Granges in both Stockholm and Perth to map out the relationship and we are now conducting further discussions around research projects and a pre-order for an RMP1 Printer," Mr. David Budge CEO said.

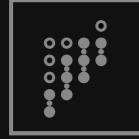

ADDITIVENOW

# Additive Now

AdditiveNow™ the Company's 50/50 incorporated joint venture (JV), commenced work with clients earlier this year.

AdditiveNow™ aims to provide a complete additive manufacturing (AM) consulting service, primarily for oil & gas, mining and major infrastructure clients by bringing together Aurora's products and technology with an existing substantial network to most major mining and oil & gas companies in the world.

One aspect of the joint venture combines Aurora's Rapid Manufacturing Technologies (RMT) with engineering expertise from Advisian Digital to design, produce and deploy complex components. Other services include provision of education on use of and design for AM as well as conversion services from legacy conventional design to AM ready designs on an industrial scale.

Visit the website to read more: [additivenow.com/](https://additivenow.com/)

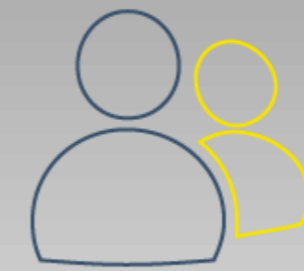

Advisory

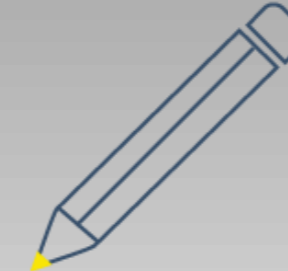

Design

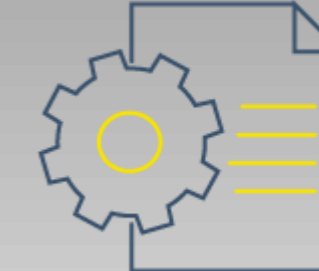

Print to Qualify

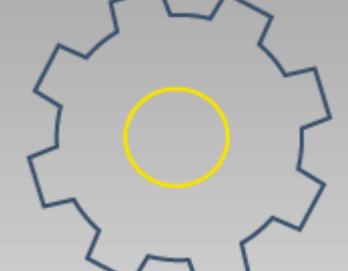

Agile Production

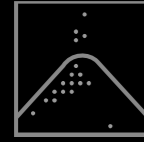

POWDERS

# Superior Powders

Aurora's activities in the powders and consumables markets has expanded to include strategic discussions with some of the largest powder manufacturers in the world that can deliver the quantities and prices that will ensure cost competitiveness when combined with very fast print speeds.

We continue to research the use of our patent pending technologies to manufacture powders of almost any metallic powder and they look promising, but our primary R&D and testing efforts are now focused on the RMP-1 Beta. We see the RMP-1 as the main driver for AM powder use when it is fully developed.

We see new or hard to use materials as very important to achieving the maximum benefit from additive manufacturing in general so we have signed the term sheet with Gränges to explore the development of materials that may be particularly suited to 3D metal printing. These will offer performance improvements for specific purposes beyond conventional materials.

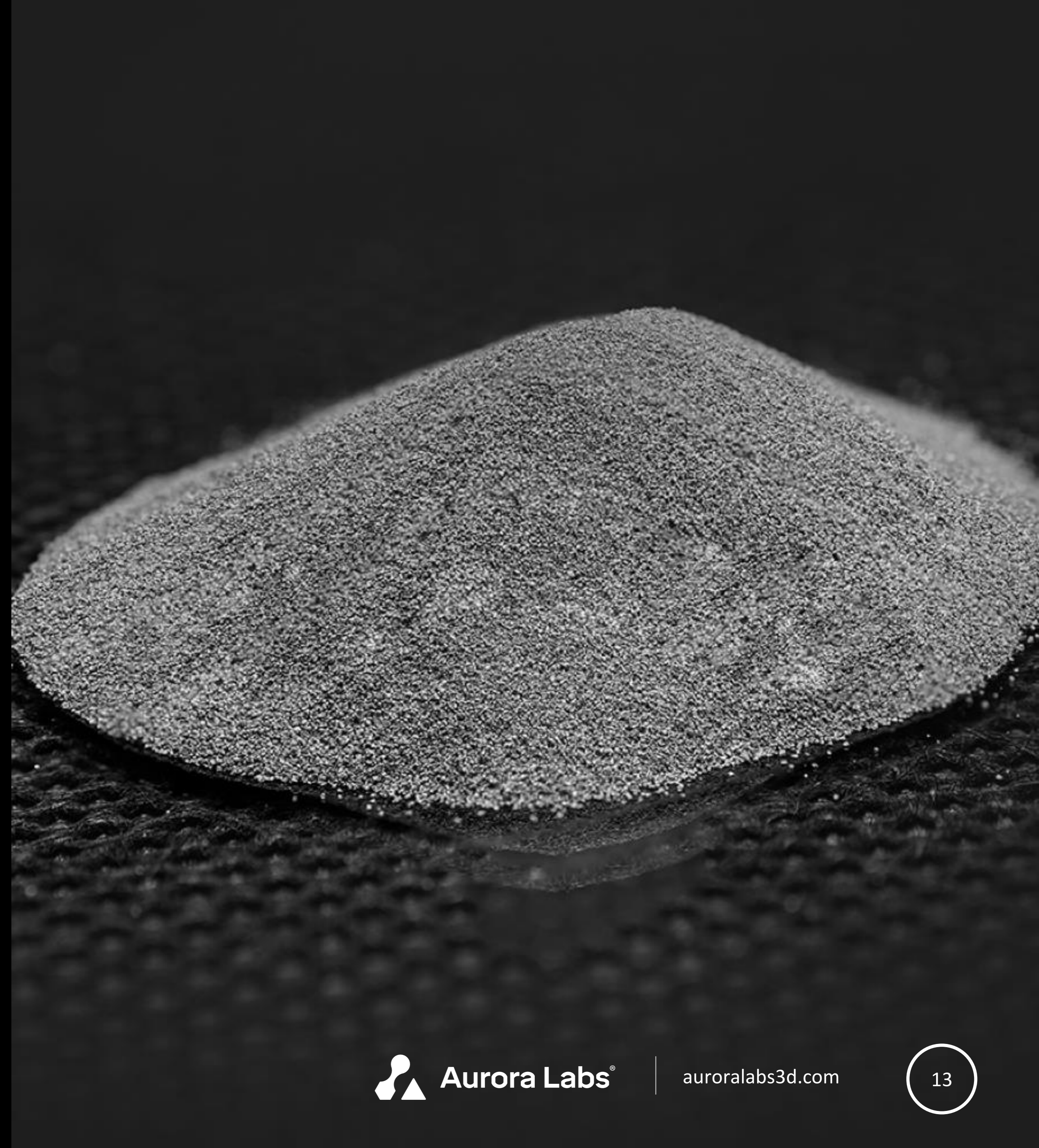



# Certification

The RMP-1 Beta already has a number of the features, such as various types of camera and custom software, that will be the backbone of data acquisition, manipulation, optimisation and storage. This patent pending technology will be implemented in the production versions of the RMP-1.

The ultimate aim is to use the data to create a verification file that each layer is printed within the parameters it should be to ensure the parts are fit for purpose or meets an external specification.

We are currently working under a term sheet with DNV-GL to create a process for control of external inputs that may affect the quality of prints. This will give us a whole of process solution for producing certified parts anywhere in the world that our printers are being used.

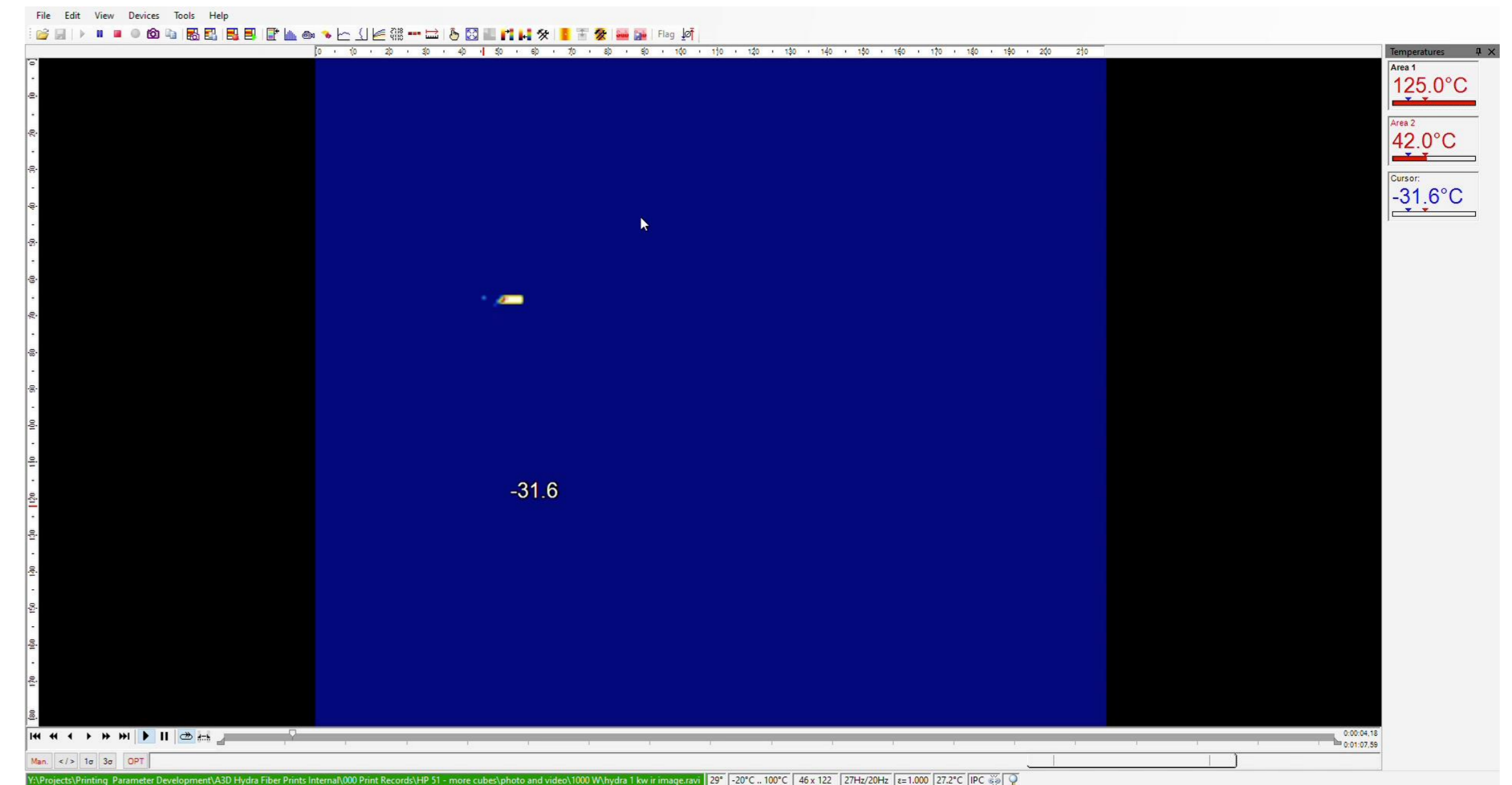

## VIDEO

Heat Map Certification

# US Facility

With a large number of S-Titanium Pro printers now being installed and plans to supply RMP-1s to interested parties over the next year in North America we are opening a Corporate office to provide product service, support, sales and general corporate services to the American market. We have established a wholly owned subsidiary, Aurora Labs 3D US LLC, which is intended to be domiciled in the Dallas, Texas area. Initial staff are have been hired with the appointment of a Senior VP. Our extensive search for a suitable facility is nearing completion with a lease document under review. We hope to secure the property and occupy the premises by Jan/Feb 2020.

Dallas is centrally located with great access to the manufacturing and oil and gas centres of the US and is in close proximity to the offices of several organisations we are already in contact with.

It is intended to use the Dallas facility as our US showroom and for the production of parts for IPPs, commercial clients and prospective purchasers. We believe the real world demonstration of the speed parts can be manufactured in will be one of the most effective ways to show the cost benefit our 3D metal printing ecosystem represents.



Aurora Labs  
Dallas Facility

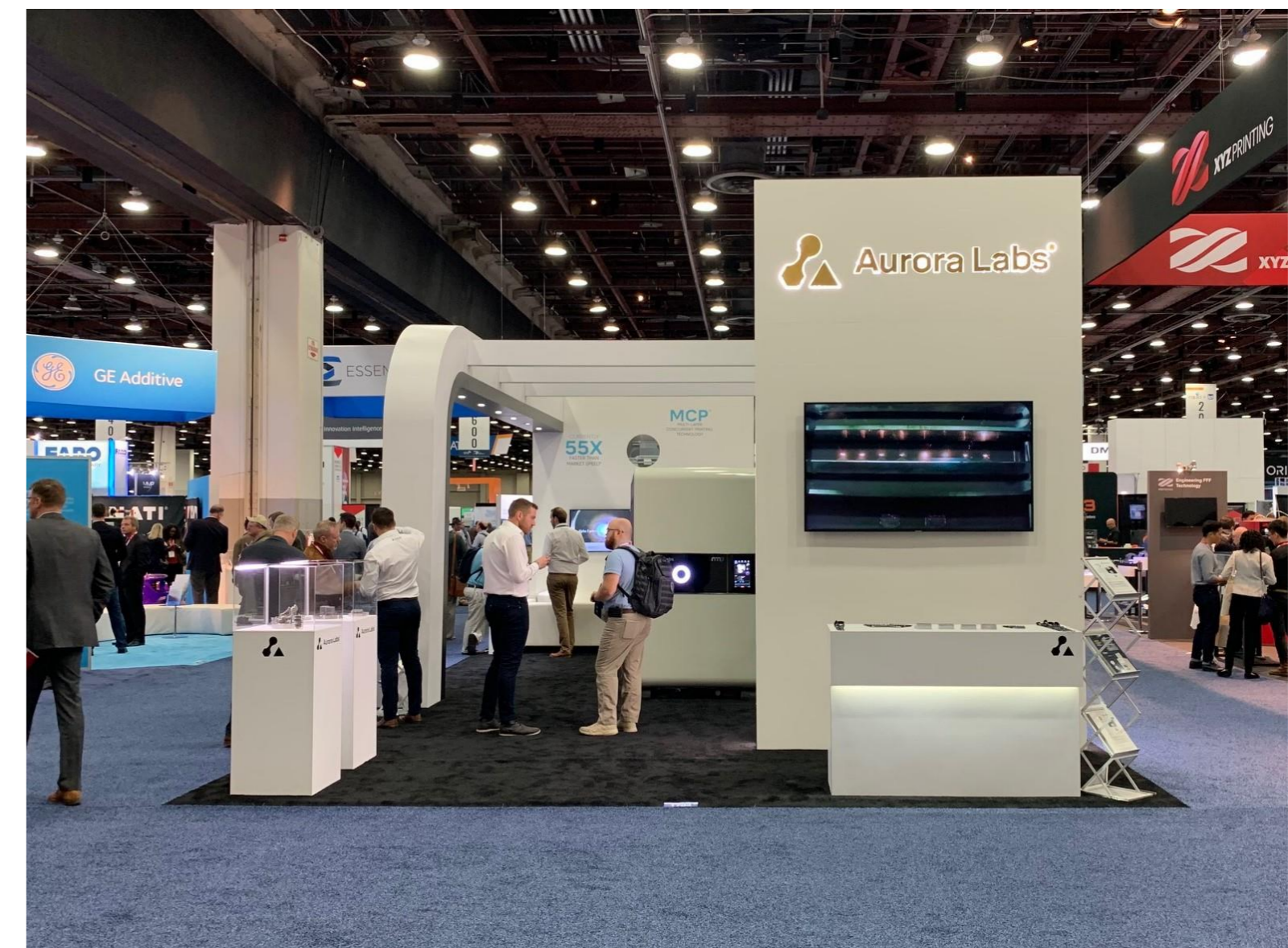

## IMAGES

Top: US Showroom – Dallas Facility,  
Bottom: Aurora Labs' stand at Rapid+TCT 2019 Tradeshow

## CONTACT US



AURORA LABS LTD.

---

U2/79 Bushland Ridge

Bibra Lake, WA

AUSTRALIA 6163

[enquiries@auroralabs3d.com](mailto:enquiries@auroralabs3d.com)

+61 (0) 8 9434 1934

[auroralabs3d.com](http://auroralabs3d.com)